

Installation Instructions

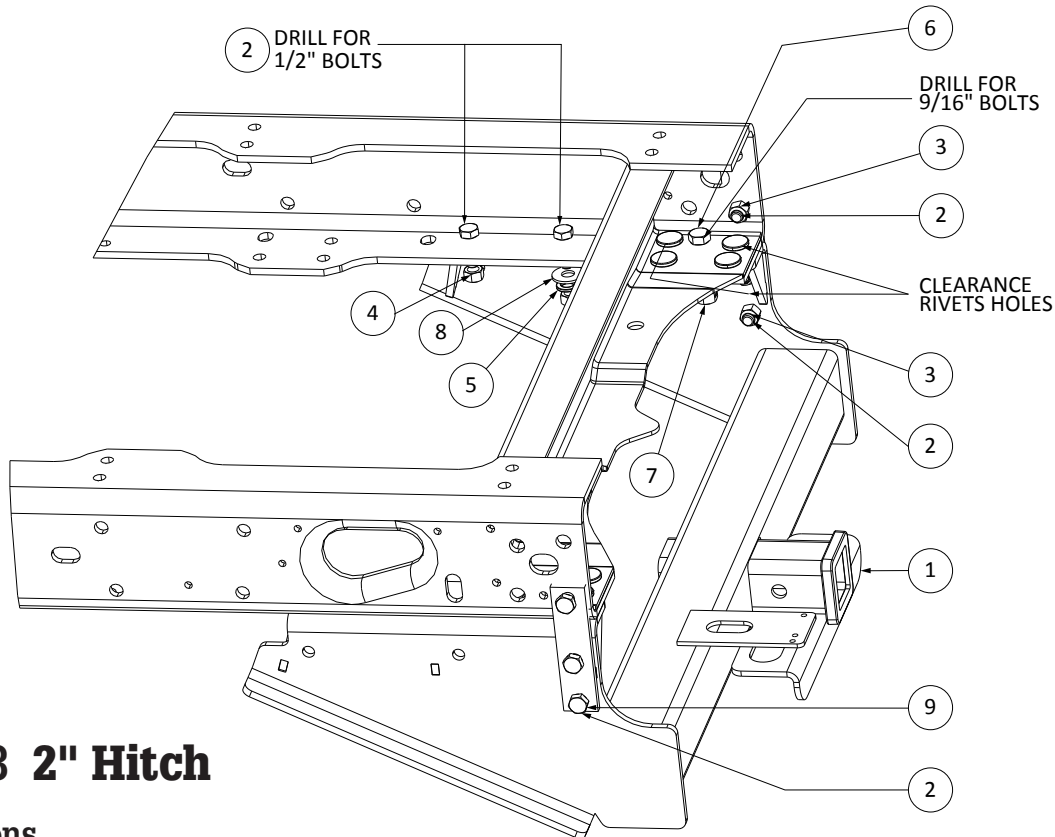

1801213 2" Hitch

Applications

2011+ Ford F450/550 Cab and Chassis
 with 34 inch wide Frame

Capacity

16,000 lbs. Maximum Gross Trailer Weight (MGTW)
 1,600 lbs. Maximum Vertical Load (MVL)

1. Place the Hitch so the large holes in the bracket are over the flat rivet heads in the frame and the hitch is resting flat against the frame. Make sure the hitch is center and clamp it down tight.

- Using the bracket as a template, mark all the holes with appropriate marking tools. You may have to spay with paint color to better see the location.
- After marking, unclamp the hitch from the frame. Start on the driver-side of the truck, drill one 19/32" hole toward the rear of the truck. Drill the next two holes with 9/16" diameter drill.
- Place the hitch back onto the frame and align it to the newly drilled holes. Secure it to the frame with the bolts, washers, and nuts - provided.
- For additional support, mount the Support Bars to the sides of the Hitch. Use the 1/2" fasteners to secure the Support Bars on the frame.

WARRANTY

Buyers Products Co. warrants all truck/trailer hardware manufactured or distributed by it, to be free from defects in material and workmanship for a period of one year from date of shipment. Parts must be properly installed and used under normal conditions. Any product which has been altered, including modification, misuse, accident or lack of maintenance will not be considered under warranty. Normal wear is excluded. The sole responsibility of Buyers Products Co. under this warranty is limited to repairing or replacing any part or parts which are returned, prepaid, and are found to be defective by Buyers Products Co. Authorization from Buyers Products Co. must be obtained before returning any part. No charges for transportation or labor performed on Buyers' products will be allowed under this warranty.

Bill of Materials

ITEM	PART NO.	QTY.	DESCRIPTION
1	3018569	1	Hitch, Weld, 2.0 in. RCVR , F450-2011+
2	3006202	10	Screw, Hex HD - 1/2-13 x 1-1/2 GR 8 ZC
3	3002397	6	Locknut, Hex Nylock, 1/2-13 ZN, G8
4	FNH050013041G5	4	Nut, 12-13 Hex GR, 5 ZP
5	FWL050088013	4	Washer, Lock - 1/2 Split ZN
6	3002476	2	Screw, Hex HD Cap 9/16-18 x 2 GR8 ZN
7	FNL056018047	2	Nut, Hex 9/16-18 Center Lock ZN
8	FWF050138014	4	Washer, Flat, 500 x 1.38 x .14, ZN
9	3018568	2	Bar, Support