

# Installation Instructions

## LT25 Water Cooler Rack for Utility Landscape Trailers

### Important!

Before you begin installing:

1. Read and understand these instructions completely.
2. Verify that you have received all the parts listed in the bill of materials.

### CAUTION:

Always wear safety glasses when using power tools.

**WARNING!** Check under the trailer and/or fender for locations of brake lines and electrical wiring etc., before drilling any holes. Any damage to trailer during installation is installer's sole responsibility.

**Note:** The water cooler rack must be mounted with back and bottom support or back support. This rack is not to be mounted with bottom support only.

## Utility Trailer Installation Instructions

### Tools Required:

- Two 9/16" wrenches and/or sockets
- Electric drill
- 13/32" drill bit

1. Find a location on your trailer where the water cooler rack can be mounted with back and bottom support or back support. **Make sure the rack does not extend past the widest part of the trailer.** Holding the rack level mark three hole locations.
2. Drill 13/32" holes in the positions marked.

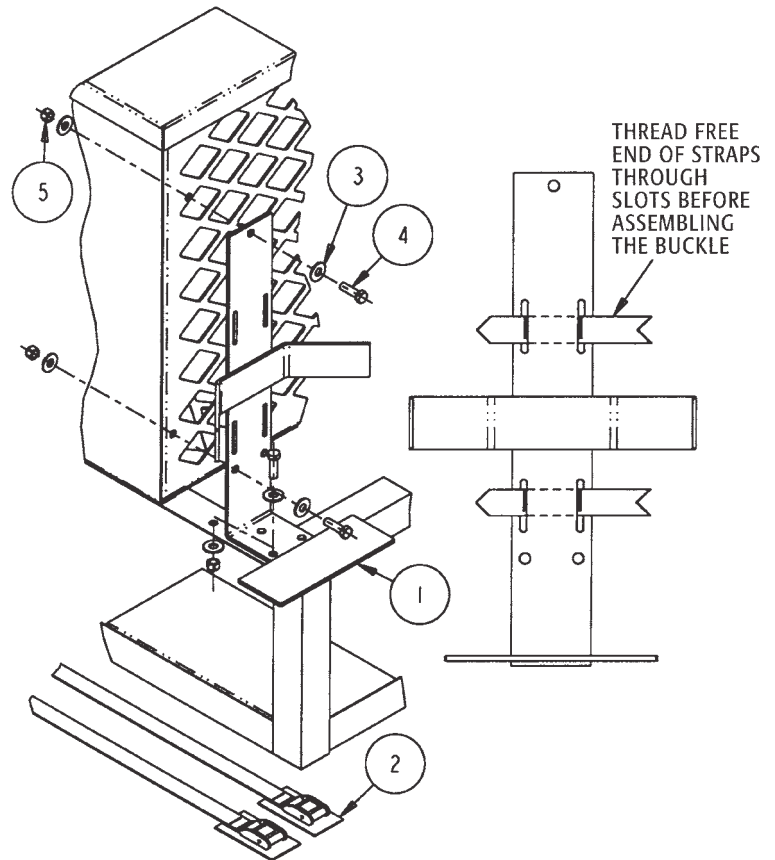

### Bill of Materials

ITEM	PART NO.	QTY.	DESCRIPTION
1	3000050	1	Water Cooler Rack, Weldment
2	3004710	2	Strap, 60" Lashing w/Cam Buckle
3	-	6	Washer, Flat 3/8 USS Zn
4	-	3	Screw, HHC 3/8-16 x 1-1/4 Gr 5 Zn
5	-	3	Nut, Nylock 3/8-16 x 7/16 Zn

3. Thread straps through the slots in the rack and then the buckle as shown in the illustrations.
4. Bolt the rack to the trailer with three 3/8-16 x 1-1/4 screws, six 3/8" flat washers, and three 3/8-16 nylock nuts and tighten.
5. Assemble the water cooler into the rack and tighten straps. Cut off the end of each strap approximately 6-8" from buckle and carefully burn the ends with a cigarette lighter to prevent fraying.

—continued on other side

## Enclosed Trailer Installation Instructions

### Tools and Materials Required:

- 9/16" wrench or socket
- Electric drill
- 1/4" drill bit
- 3/4" plywood shim strips
- Shim screws

**1.** In order to mount this rack to an enclosed trailer, **you must first add 3/4" plywood shim strips to the walls.** These shim strips must be attached to at least two wall support studs with suitable fasteners. If you don't know what kind or length of fastener to use contact your trailer dealer or manufacturer for their recommendation. The shim strips should not completely cover the four slots in the water cooler rack. One inch of each slot needs to be unobstructed for strap attachment.

**2.** Place the rack against the shims, hold level, and mark the position of the three 3/8" holes in rack.

**3.** Drill three 1/4" holes in the center of your marks 1" deep. **Be extremely careful not to drill through the outside trailer wall.**

**4.** Fasten the rack to the trailer wall with three 3/8" lag screws and three 3/8" flat washers supplied.

**5.** Thread straps through the slots in the rack and then the buckle as shown in the illustrations.

**6.** Assemble the water cooler into the rack and tighten straps. Cut off the end of each strap approximately 6-8" from buckle and carefully burn the ends with a cigarette lighter to prevent fraying.

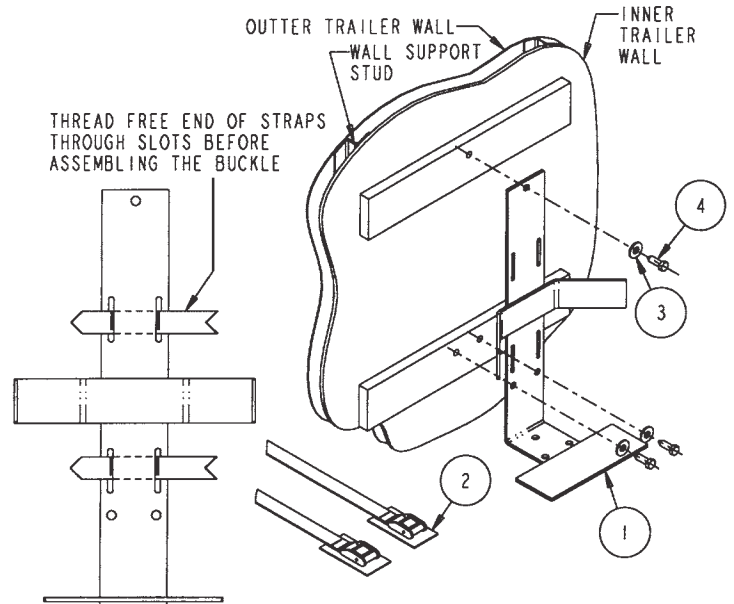

### Bill of Materials

ITEM	PART NO.	QTY.	DESCRIPTION
1	3000050	1	Water Cooler Rack, Weldment
2	3004710	2	Strap, 60" Lashing w/Cam Buckle
3	-	3	Washer, Flat 3/8 USS Zn
4	-	3	Screw, Hex Head Lag, 3/8 x 1-1/4 Zn

### Warranty Information

Buyers Products warrants all truck/trailer hardware manufactured or distributed by it, to be free from defects in material and workmanship for a period of one year from date of shipment. Parts must be properly installed and used under normal conditions. Any product which has been altered, including modification, misuse, accident or lack of maintenance will not be considered under warranty. Normal wear is excluded. The sole responsibility of Buyers Products under this warranty is limited to repairing or replacing any part or parts which are returned, prepaid, and are found to be defective by Buyers Products. Authorization from Buyers Products must be obtained before returning any part. No charges for transportation or labor performed on Buyers' products will be allowed under this warranty.