

Installation Instructions

Accessories for Window Protectors

This instruction sheet describes installation of the following accessories:

- **Load Guide Kit, #85130**
- **Kit for Strobe Light 6-1/2" OD, #85140**
- **Kit for Utility Light 10-1/4" OD, #85145**
- **Kit for Minilight Bar, #85150**
- **Kit for Antenna/Spotlight, #85155**

Important: Installation Instructions, Warranty Information. *Place in vehicle glove box after installation.*

GENERAL INFORMATION

CAUTION:

- 1.** Park your vehicle on flat, horizontal surface. Apply parking brake or use wheel chocks to prevent accidental rolling.
- 2.** To keep debris out of your eyes always wear protective eyewear.
- 3.** Check contents of box against part list to make sure all components is included.

TOOLS REQUIRED:

Two 7/16" Wrenches, Open or Socket

Load Guide Kit Installation

- 1.** Place U-shaped base of the Load Guide over upper tubing of the Window Protector in desired location.
- 2.** Install all hardware *as shown in Fig.1*. Make sure to place spacers into opening of U-shaped base to prevent collapsing of this part.
- 3.** Tighten nylock nuts to 20-30 ft-lbs. of torque.

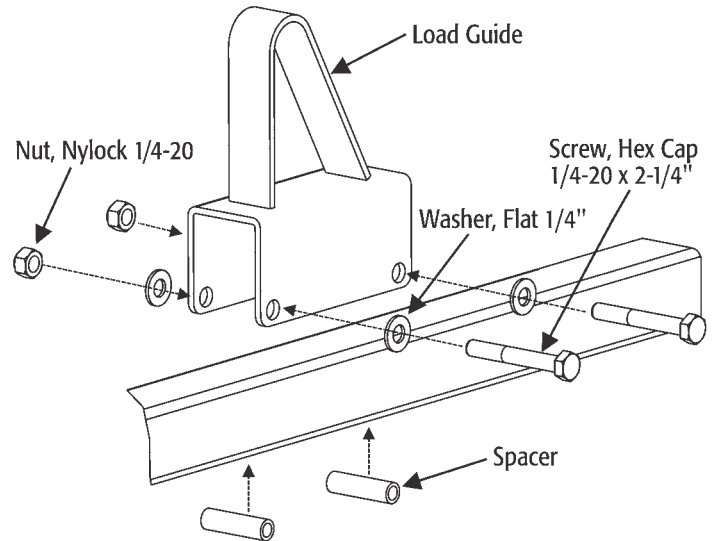

Fig. 1

PART NO.	QTY.	DESCRIPTION
3003335	2	Load Guide
3003913	4	Spacer
FNE025020031	4	Nut, Nylock 1/4-20
FWF025063007	8	Washer, Flat 1/4"
3004435	4	Screw, Hex Cap 1/4-20 x 2-1/4"
3003919	1	Instruction Sheet

-continued

FULL ONE-YEAR WARRANTY

Manufacturer will repair, or at manufacturer's discretion will replace any part of this Window Protector which proves to be defective in workmanship or material under normal use for period of one year from the date of delivery to the original purchaser. Any cost incurred in returning the product to the supplier is the responsibility of the consumer.

EXCLUSIONS

Manufacturer shall not to be liable for special, incidental, or consequential damages or for damages resulting from lack of necessary maintenance, from misuse, abuse, act of God, or alteration of the product. Some states do not allow the exclusion or limitation of incidental or consequential damages, so the above limitation or exclusion may not apply to you.

Kit for Strobe Light 6-1/2" OD Installation

1. Place U-shaped base of the Bracket for Strobe Light over upper tubing of the Window Protector in desired location.
2. Install all hardware *as shown in Fig.2*. Make sure to place spacers into opening of U- shaped base to prevent collapsing of this part.
3. Tighten nylock nuts to 20-30 ft-lbs. of torque.

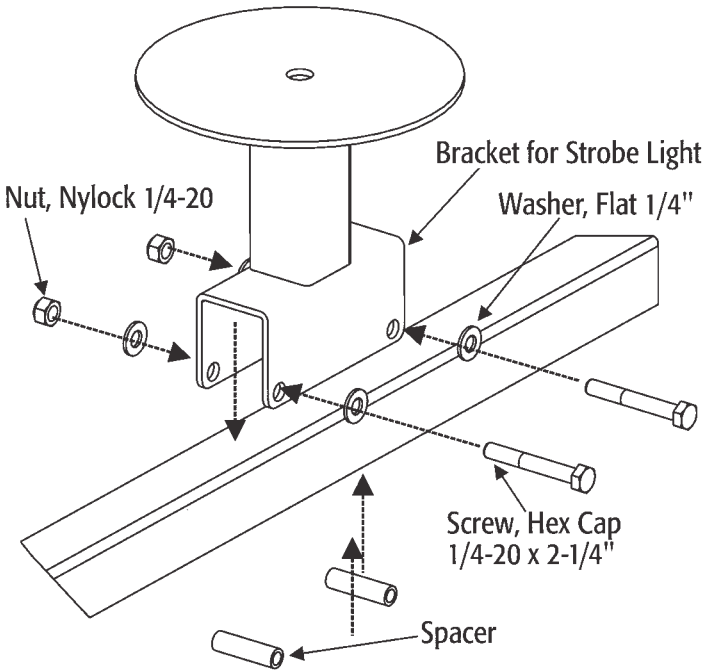

Fig. 2

PART NO.	QTY.	DESCRIPTION
30034452	1	Bracket for Strobe Light
3003913	2	Spacer
FNE025020031	2	Nut, Nylock 1/4-20
FWF025063007	4	Washer, Flat 1/4"
3004435	2	Screw, Hex Cap 1/4-20 x 2-1/4"
3003919	1	Instruction Sheet

Kit for Utility Light 10-1/4" OD Installation

1. Place U-shaped base of the Bracket for Utility Light over upper tubing of the Window Protector in desired location.
2. Install all hardware *as shown in Fig.3*. Make sure to place spacers into opening of U- shaped base to prevent collapsing of this part.
3. Tighten nylock nuts to 20-30 ft-lbs. of torque.

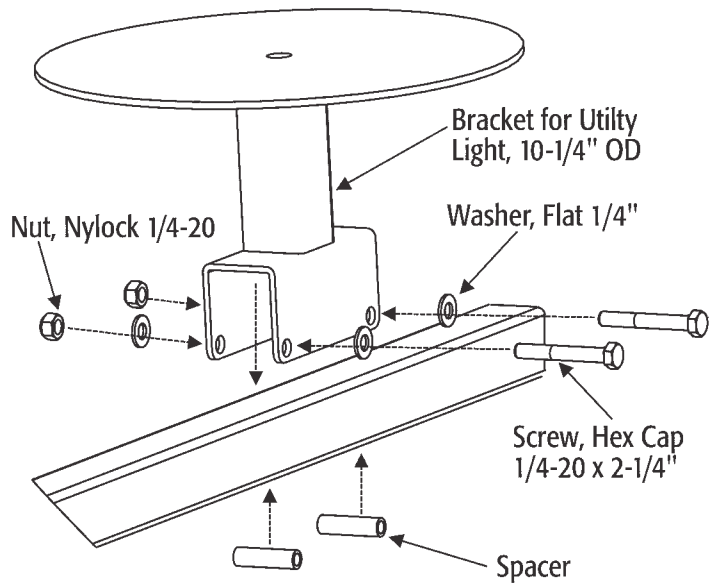

Fig. 3

PART NO.	QTY.	DESCRIPTION
3003916	1	Bracket for Utility Light, 10-1/4" OD
3003913	2	Spacer
FNE025020031	2	Nut, Nylock 1/4-20
FWF025063007	4	Washer, Flat 1/4"
3004435	2	Screw, Hex Cap 1/4-20 x 2-1/4"
3003919	1	Instruction Sheet

Kit for Minilight Bar Installation

1. Place U-shaped base of the Bracket for Minilight Bar over upper tubing of the Window Protector in desired location.
2. Install all hardware *as shown in Fig.4*. Make sure to place spacers into opening of U-shaped base to prevent collapsing of this part.
3. Tighten nylock nuts to 20-30 ft-lbs. of torque.

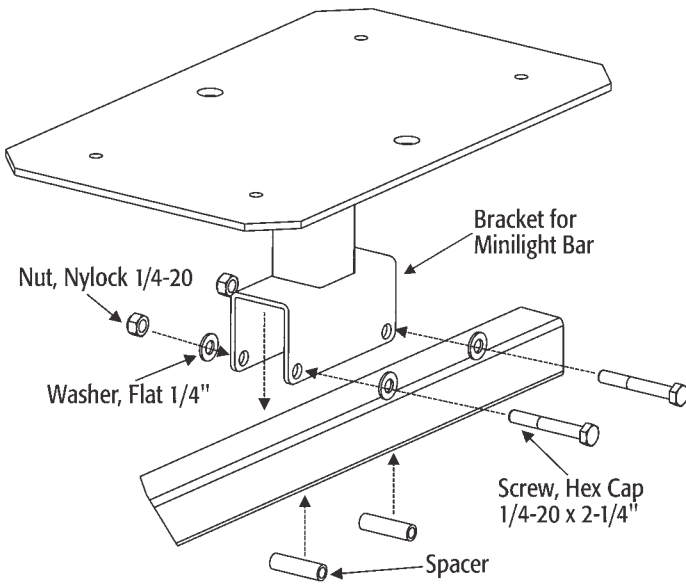

Fig. 4

PART NO.	QTY.	DESCRIPTION
3002761	1	Bracket for Minilight Bar
3003913	2	Spacer
FNE025020031	2	Nut, Nylock 1/4-20
FWF025063007	4	Washer, Flat 1/4"
3004435	2	Screw, Hex Cap 1/4-20 x 2-1/4"
3003919	1	Instruction Sheet

Kit for Antenna/ Spotlight Installation

1. Place U-shaped base of the Bracket for Antenna/ Spotlight over upper tubing of the Window Protector in desired location.
2. Install all hardware *as shown in Fig.5*. Make sure to place spacers into opening of U-shaped base to prevent collapsing of this part.
3. Tighten nylock nuts to 20-30 ft-lbs. of torque.

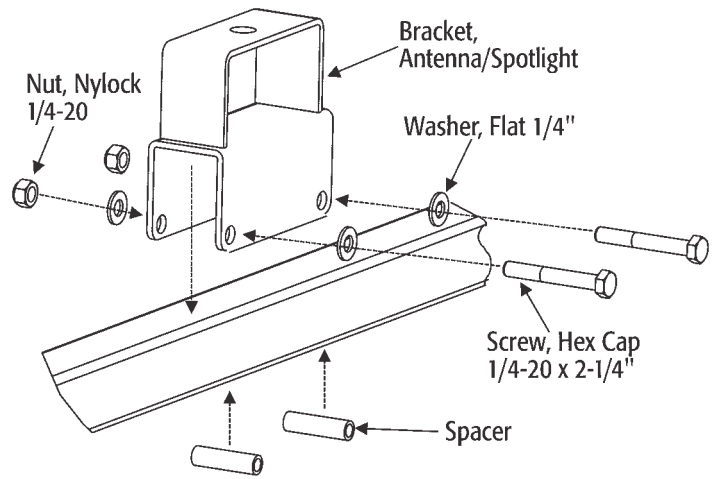

Fig. 5

PART NO.	QTY.	DESCRIPTION
3003454	1	Bracket for Antenna/Spotlight
3003913	2	Spacer
FNE025020031	2	Nut, Nylock 1/4-20
FWF025063007	4	Washer, Flat 1/4"
3004435	2	Screw, Hex Cap 1/4-20 x 2-1/4"
3003919	1	Instruction Sheet