

# Rebuild Instructions

## Tie-Rod Cylinder Rebuild Instructions

Use these instructions for the following replacement parts kits:

### TGC25XFCK Front Cap Replacement Kit:

Leakage around the cylinder's rod by the rod seals will normally indicate that the front cap needs to be replaced.

### TGC25XPRK Piston Replacement Kit:

Leakage from non-pressurized port will normally indicate that the cylinder's piston cup needs to be replaced. For example... When the cylinder is retracted, air comes out of rear cap's port. When cylinder is extended, air leaks out of the front cap's port. One or both of these conditions may occur if the piston cup needs to be replaced.

### TGC25XRCK Rear Cap Replacement Kit:

The rear cap should be replaced if the clevis is damaged or if the port threads have been stripped.

### Cylinder Disassembly and Inspection:

1. Remove any hardware that may be assembled to the rod's thread. Clean off any debris that may be on the shaft.
2. Remove the four nuts and slide out the tie-rod screws.
3. Carefully slide the front cap over the rod and threads.
4. Clean and inspect bushing and seals for excessive wear. The bushing and seals are permanently mounted in the front cap. Replace front cap if there is excessive wear to either of the seals or bushing.

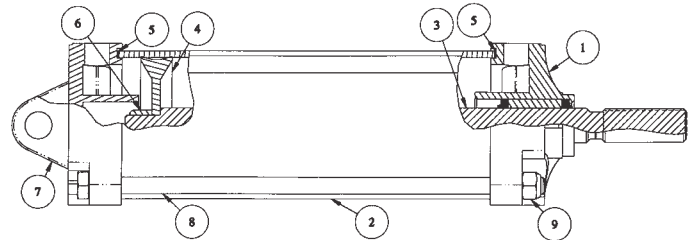

CYLINDER COMPONENTS			SERVICE PART KIT COMPONENTS		
ITEM	DESCRIPTION	QTY.	TGC25XFCK	TGC25XPRK	TGC25XRCK
1	Front Cap Assembly	1	1	-	-
2	Cylinder Tube	1	-	-	-
3	Piston Rod	1	-	-	-
4	Piston Cup	1	-	1	-
5	Cap Gasket	2	2	2	2
6	3/8-24 Nylock Nut	1	-	-	-
7	Rear Clevis Cap	1	-	-	1
8	5/16-18 Tie-Rod Screw	4	-	-	-
9	5/16-18 Nylock Nut	4	-	-	-

5. Remove the cap gaskets from both caps and clean the gasket seats for reassembly.
6. Slide piston out of the tube. Clean and inspect piston and tube for any excessive wear or damage. Light scratch marks on the inside of the cylinder will generally have no detrimental effects on the performance of the cylinder.

### Piston Replacement:

If you are assembling a cap replacement kit, skip to step nine.

6. Hold the piston rod on the flats located near the threads with a 1/2" wrench while loosening the 3/8" nut holding the piston cup.
7. Remove old piston cup and assemble the new piston cup with the urethane side facing towards the shaft end of the rod.
8. Assemble and tighten the 3/8" nut to secure the piston cup to the piston rod.

—continued on other side

**Continue here for Cap Replacement and Cylinder Reassembly:**

- 9.** Lubricate the urethane piston cup and the inside of the cylinder tube with the grease supplied.
- 10.** Place the center of the piston cup on the inside edge of the cylinder tube and carefully rotate the piston cup into the tube. *See Fig. 1.* Then, slide piston assembly into the cylinder tube.
- 11.** Lubricate the bushing and seals of the front cap and the cylinder shaft with the grease supplied.
- 12.** Assemble a cylinder cap gasket into the gasket seat in the front cap and slide cap assembly over the shaft until it is against the cylinder tube.
- 13.** Assemble the tie-rod screws into the four holes in the rear cap. With the tie-rod in position, assemble the cylinder cap gasket into the gasket seat.

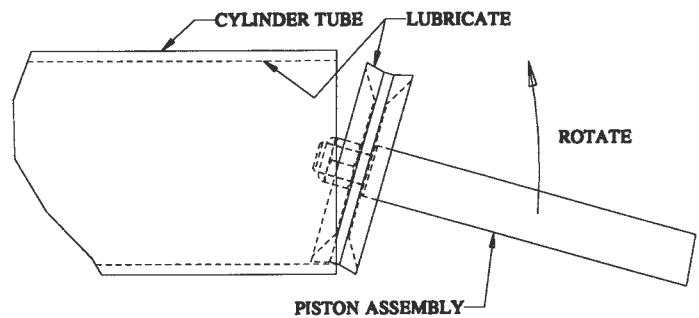

**Fig. 1**

- 14.** Slide the rear cap assembly onto the other end of the cylinder tube sliding the tie-rods into the holes in the front cap. Make sure the cylinder ports in each cap are in the desired position.
- 15.** Hand tighten the four nuts holding the cylinder together.
- 16.** Make sure the cylinder cap gaskets are in the proper position and torque the nuts to 72 in-lbs. using opposite corner to corner torquing

**Warranty Information**

Buyers Products Co. warrants all truck/trailer hardware manufactured or distributed by it, to be free from defects in material and workmanship for a period of one year from date of shipment. Parts must be properly installed and used under normal conditions. Any product which has been altered, including modification, misuse, accident or lack of maintenance will not be considered under warranty. Normal wear is excluded. The sole responsibility of Buyers Products Co. under this warranty is limited to repairing or replacing any part or parts which are returned, prepaid, and are found to be defective by Buyers Products Co. Authorization from Buyers Products Co. must be obtained before returning any part. No charges for transportation or labor performed on Buyers' products will be allowed under this warranty.