

Installation Instructions

Steel Floor Mount TRUCK RACK Model 1501010

Bill of Materials

QTY.	DESCRIPTION
2	Front Posts
2	Rear Posts
4	Siderails
1	Rear Cross Bar
1	Blank Cross Bar
1	Cross Bar Ends
6	Clamps
4	3/8"-16 x 2 1/2" Hex Head Bolt
5	3/8"-16 x 5/8" Hex Head Bolt
32	3/8"-16 x 1" Carriage Bolt
36	3/8"-Hex Nuts
36	3/8"-Lock Washer
36	3/8"-Flat Washer
2	Locking Pins

NOTE: Front Posts have welded NUTS
Rear Posts have through holes

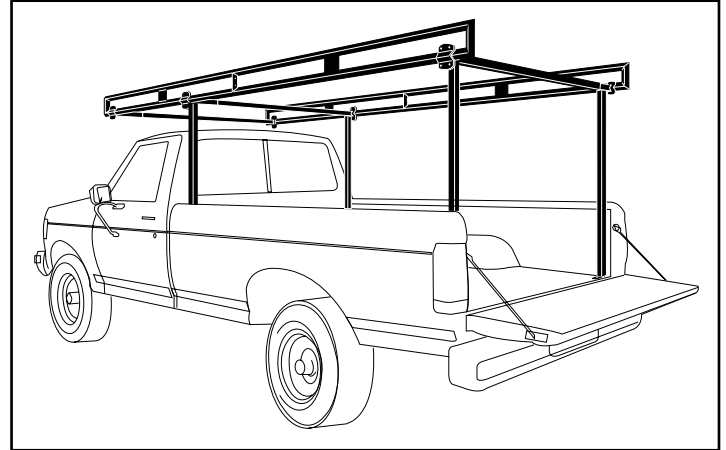

Tools Needed for Assembly

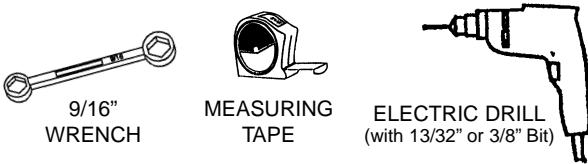

**READ ALL INSTRUCTIONS
 BEFORE STARTING ANY
 INSTALLATION**

**CAUTION!
 CAREFULLY INSPECT
 AREAS TO BE
 DRILLED ON
 VEHICLE PRIOR TO
 DRILLING ANY HOLES
 FOR POSSIBLE
 HAZARDS
 AND OBSTRUCTIONS**

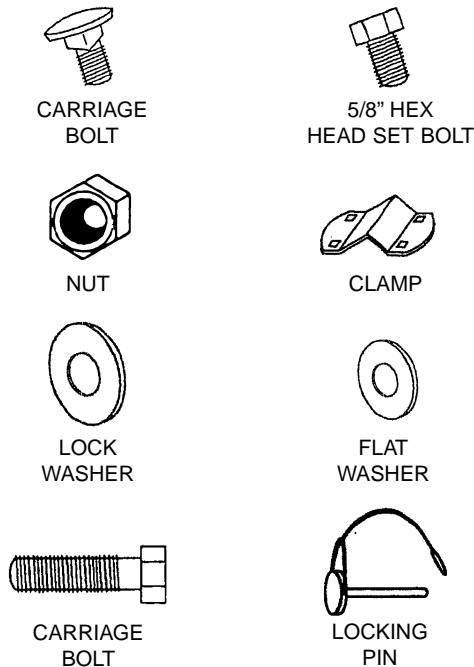
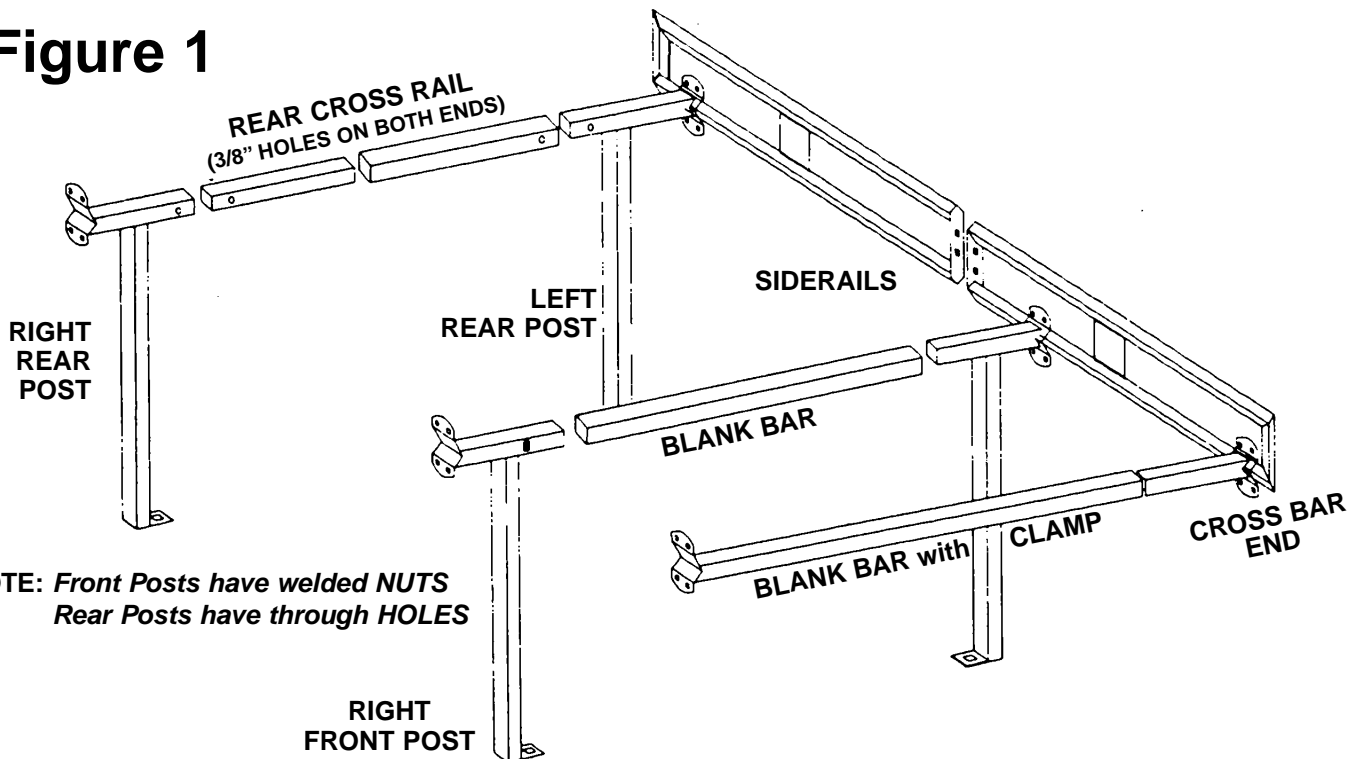

Figure 1



**NOTE: Front Posts have welded NUTS
 Rear Posts have through HOLES**

Assembly

1. Position the Left and Right **Rear Corner Posts** as close to the rear corners as tail gate and other mechanisms allow. (Posts should be square against bed rail). Mark where holes are to be drilled on the bed floor.

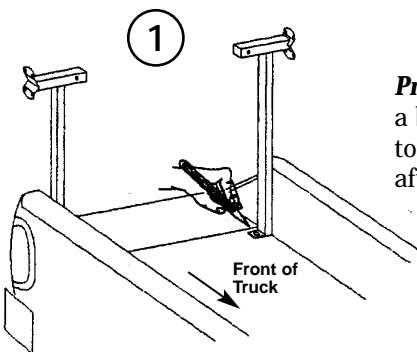

Preparation: If you have a bed liner, you will have to remove it and reinstall after rack installation.

2. Using a 13/32" or 3/8" drill bit, drill holes (2) where marked.

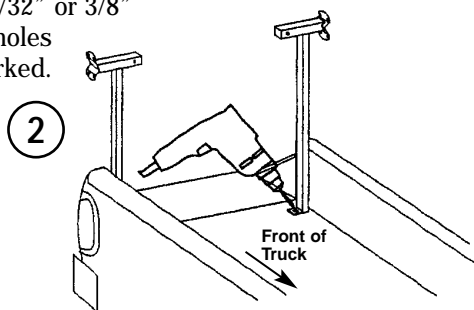

3. Mount rear posts to bed floor. Secure using (per hole):

- 1 - 3/8" - 16 x 1" carriage bolt
- 1 - 3/8" - flat washer
- 1 - 3/8" - lock washer
- 1 - 3/8" - hex head nut

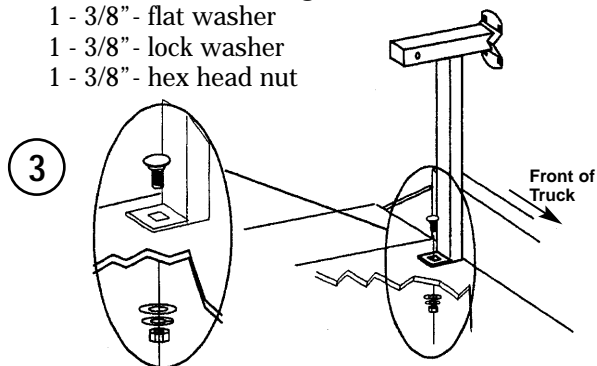

4. Be sure Posts are vertically level against the bed rail. Drill hole directly through the center of post all the way through the bed rail.

Secure using (per hole):

- 1 - 3/8" - 16 x 2 1/2" hex head bolt
- 1 - 3/8" - flat washer
- 1 - 3/8" - lock washer
- 1 - 3/8" - hex head nut

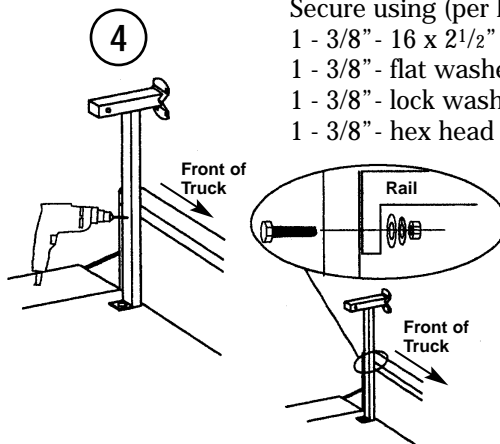

5. After rear posts are secured and tightened with a 9/16" wrench, identify the Rear bar (telescoping tube with 3/8" pre-drilled holes on either end), and insert into left & right rear post making sure:

- A. Tubes are compatible and match.
- B. Pre-drilled holes match those on corner posts
- C. Welded nuts face down

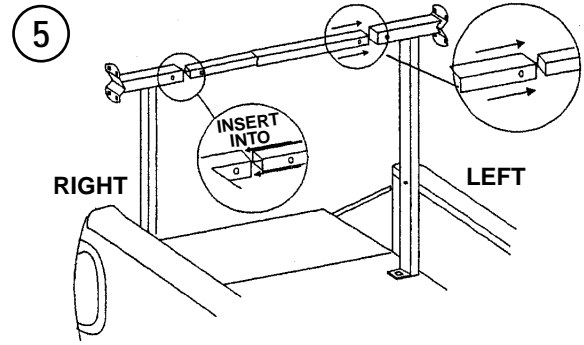

6. Secure **Rear Bar to Rear Posts** using Locking pins, and *hand* tighten 3/8" hex head set bolts into the weld nuts on the underside of the bars & posts.

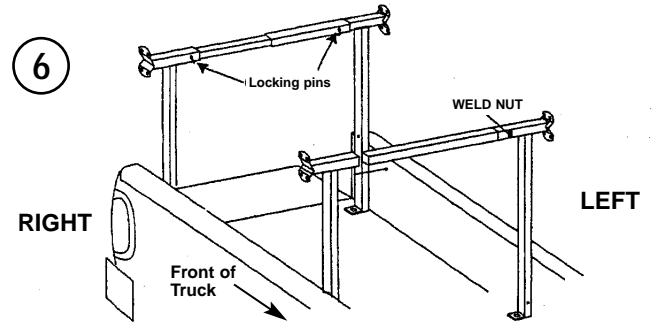

7. Position Left Front Post in place and secure (see steps 3 & 4).

8. Insert one end of the **Blank Bar** into installed front left post, and the other end into the right post. Secure right front post at this time (see steps 3 & 4). If Blank Bar is too long, you will need to trim it at this time.

9. Insert hex head set bolt into all weld nuts and hand tighten at this time.

10. Bolt two Side Rails together to make a full length side rail assembly. Repeat for the second rail. Please note the direction of the labels and assemble rails so they face the same way. (see below)

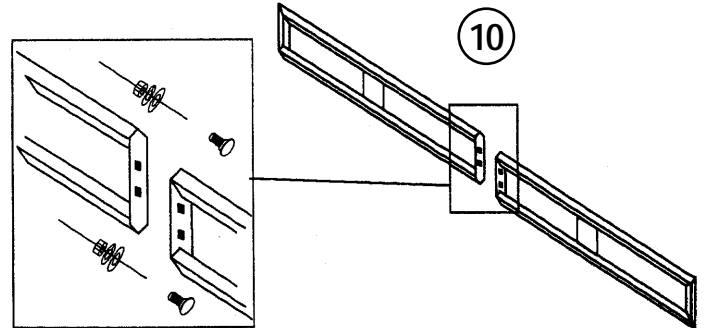

- Secure with the following: (per side)
- 2-3/8" - 16x1" Carriage bolt
 - 2-3/8" - flat washer
 - 2-3/8" - lock washer
 - 2-3/8" - hex head nut

Step 11 may require the help of another person to lift side rail and secure to posts.

11. Install side rail assembly to front and Rear Posts securing with Clamp, 4 Carriage bolts, 4 lock washers, 4 flat washers and 4 nuts. Tighten with 9/16" wrench.

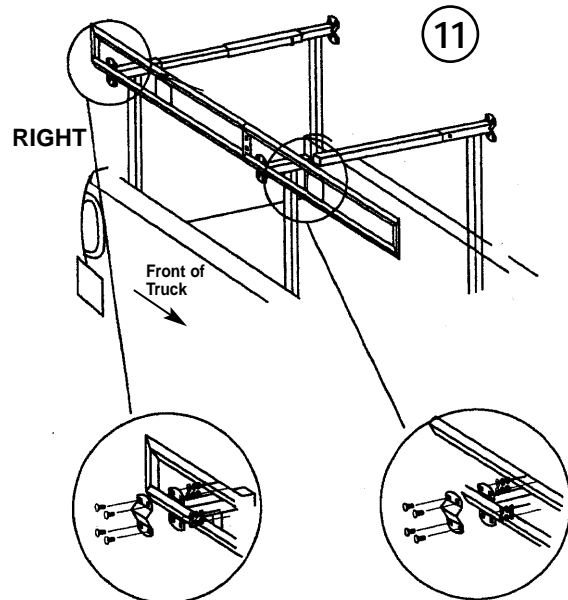

12. Repeat on opposite side.

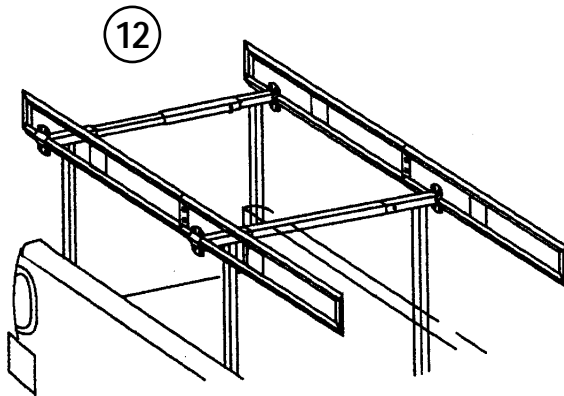

13. Install Cross Bar with Clamp in the front of the rack by inserting Crossbar end and telescoping tubes until they are extended to secure to side rails. Secure the Cross Bar end with a clamp and 4 Carriage Bolts, 4 lock washers, 4 flat washers and 4 nuts.

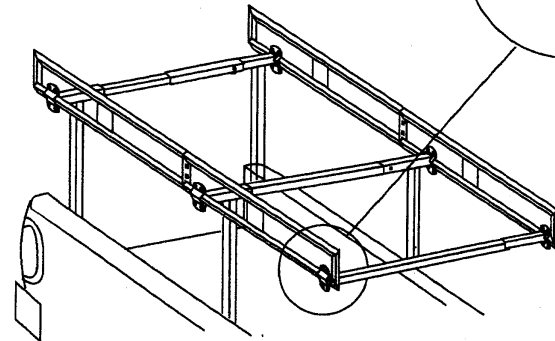
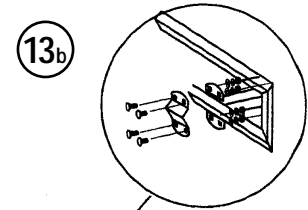
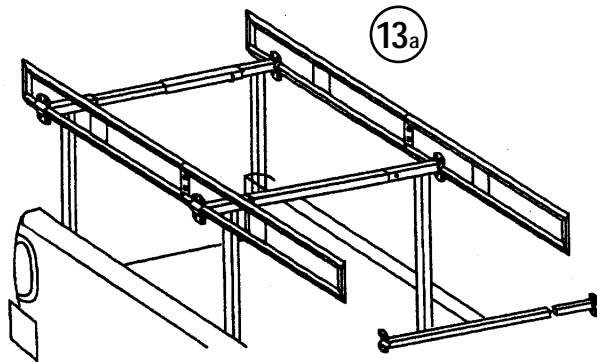

14. Secure the opposite end to side rail in the same fashion.

15. Locate weld nut on the Cross Bar with Clamp, and insert a set bolt into weld nut to set bar length and stabilize rack.

16. Insert remaining set bolts into any vacant welded nuts.

17. **BE SURE TO TIGHTEN EVERY ASSEMBLY WITH A 9/16" WRENCH TO ENSURE RACK IS SECURED.**

18. PERIODICALLY CHECK ALL HARDWARE FOR TIGHTNESS.

19. **WE RECOMMEND CAULKING GAPS WHERE TUBES TELESCOPE WITH A CLEAR SILICONE TO ELIMINATE WIND NOISE AND PROLONG THE APPEARANCE OF YOUR RACK.**

20. AS WITH ANY RACK WHICH EXTENDS OVER PASSENGER DOORS, EXERCISE CAUTION WHEN ENTERING & EXITING VEHICLE TO AVOID HEAD INJURIES.

Warranty Information

Buyers Products warrants all truck/trailer hardware manufactured or distributed by it, to be free from defects in material and workmanship for a period of one year from date of shipment. Parts must be properly installed and used under normal conditions. Any product which has been altered, including modification, misuse, accident or lack of maintenance will not be considered under warranty. Normal wear is excluded. The sole responsibility of Buyers products under this warranty is limited to repairing or replacing any part or parts which are returned, prepaid, and are found to be defective by Buyers Products. Authorization from Buyers Products must be obtained before returning any part. No charges for transportation or labor performed on Buyers' products will be allowed under this warranty.