

# Installation Instructions

## 3100/4100-Series Vernier Adjustable Locking Control Cables

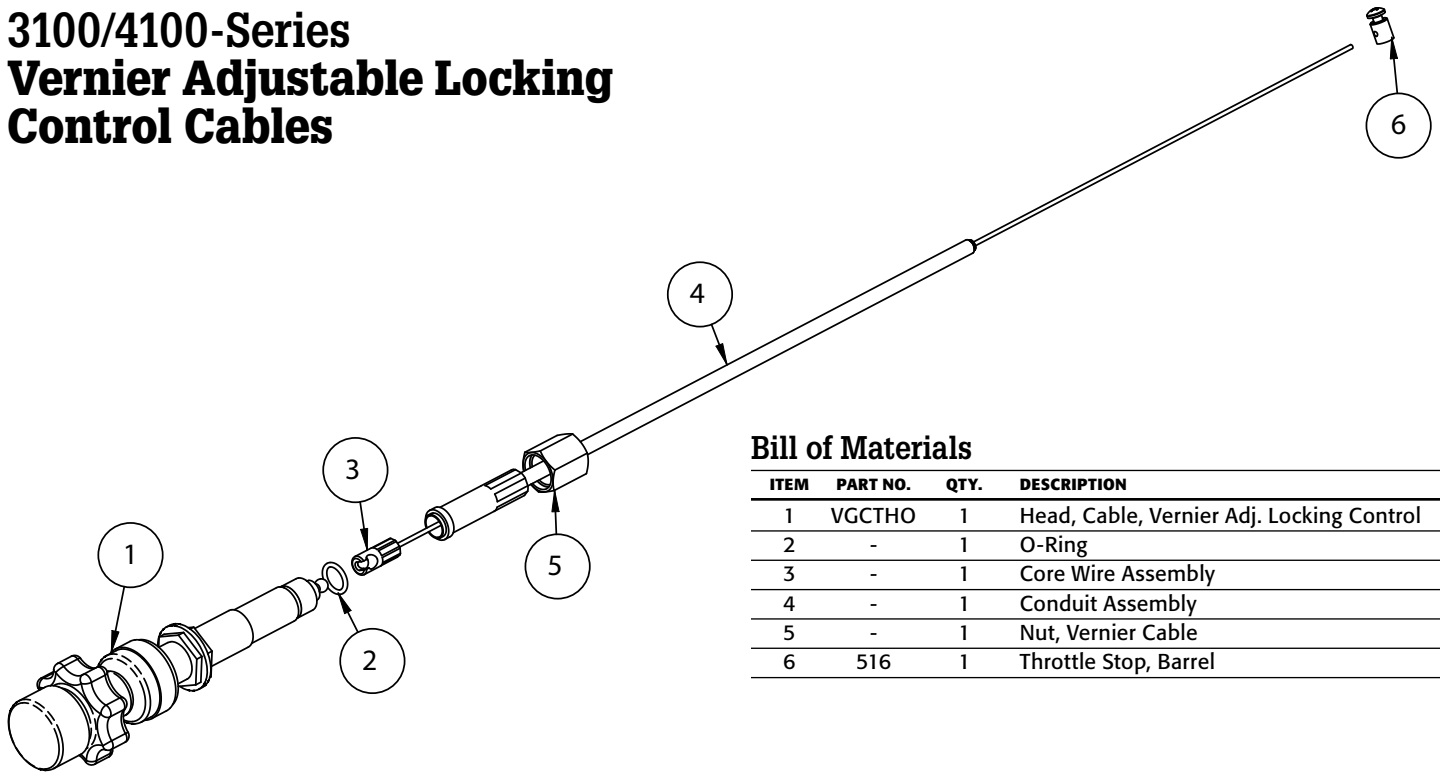

### Bill of Materials

ITEM	PART NO.	QTY.	DESCRIPTION
1	VGCTHO	1	Head, Cable, Vernier Adj. Locking Control
2	-	1	O-Ring
3	-	1	Core Wire Assembly
4	-	1	Conduit Assembly
5	-	1	Nut, Vernier Cable
6	516	1	Throttle Stop, Barrel

### Cutting Instructions *(see illustration on back)*

1. Determine the length of the cable conduit (A) and the length of exposed core wire (B) required for your application.
2. With the control head in its fully compressed position hook the spherical end into the socket of the core wire.

3. Pull the control head away from the conduit fitting until the end of the threaded portion is the same distance from the conduit fitting as the amount of exposed core wire required (B).
4. Cut the conduit and core wire at conduit length (A) required with an abrasive wheel. When the head is assembled to the conduit fitting the amount of exposed wire will be correct.

—continued on back

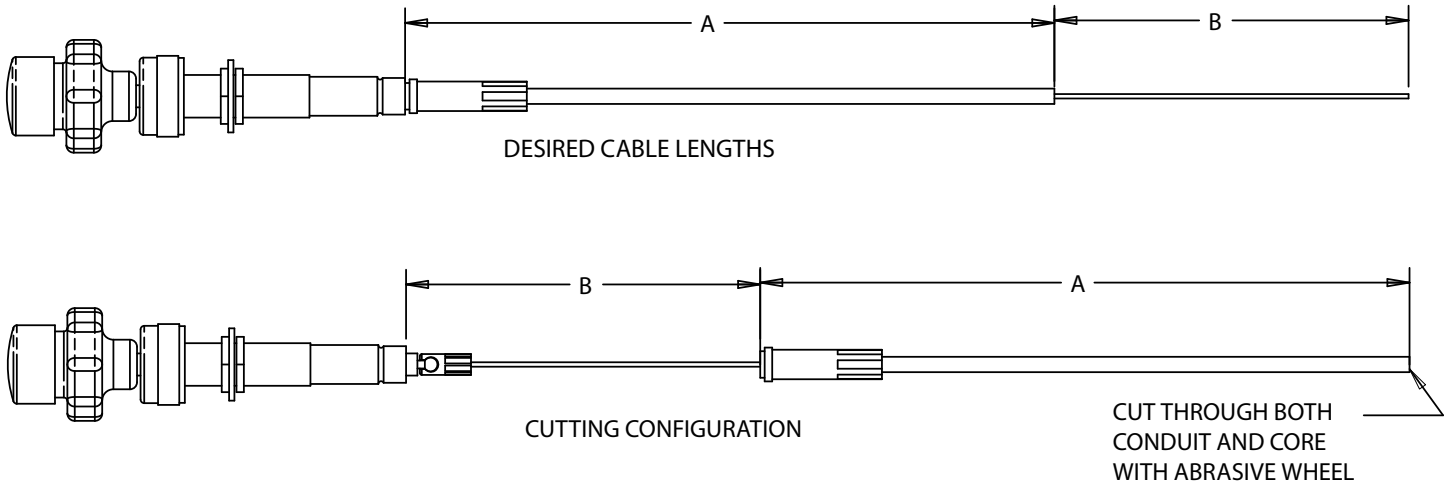

### Assembly Instructions

1. Place O-ring on the end of the conduit fitting.
2. Hook spherical end of the control head into socket on the end of the cable core.
3. Hold the O-ring in the notch on the conduit fitting and press against the control head. Tighten nut.

### Installation Instructions

1. Drill .750-.781" diameter hole in the control panel or dash board where you would like to mount the cable. Make sure the control panel or dash board is rigid and strong in the mounting location.  
**CAUTION: Be extremely careful not to drill into any existing wires or components behind the control panel or dash board.**
2. Thread cable through the hole and route it to the throttle control linkage. Tighten 3/4 nuts against each side of the mounting surface. Tie cable away from any moving or hot parts.
3. The end of the cable conduit must be mounted near the throttle linkage to work properly. You may use a conduit clamp or bulkhead fitting to hold the conduit.
4. Attach cable core to throttle linkage with the supplied throttle stop.

### Cable Routing Notes

- A.** Make sure that the cable is not bent smaller than a 6" radius. The cable should be as straight as possible to minimize the force required to pull the cable.
- B.** Make sure to route the cable away from hot components like the engine block or exhaust pipes. The recommended temperature range for the cable is -65° to +215° Fahrenheit.

#### WARRANTY

Buyers Products Co. warrants all truck/trailer hardware manufactured or distributed by it, to be free from defects in material and workmanship for a period of one year from date of shipment. Parts must be properly installed and used under normal conditions. Any product which has been altered, including modification, misuse, accident or lack of maintenance will not be considered under warranty. Normal wear is excluded. The sole responsibility of Buyers Products Co. under this warranty is limited to repairing or replacing any part or parts which are returned, prepaid, and are found to be defective by Buyers Products Co. Authorization from Buyers Products Co. must be obtained before returning any part. No charges for transportation or labor performed on Buyers' products will be allowed under this warranty.