

**NEW  
PRODUCT**

All dimensions shown are nominal.

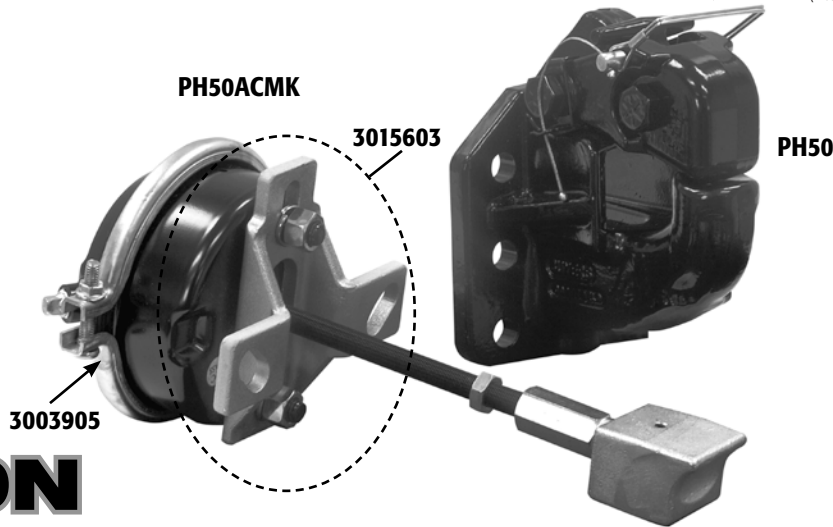
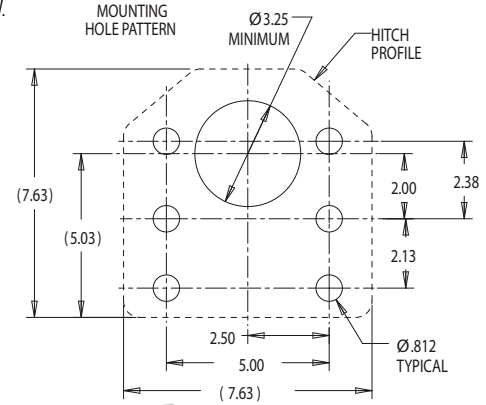
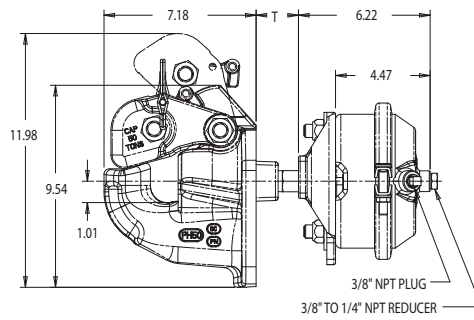

# 50-TON Pintle Hooks

- Rigid type pintle hook
- Can be utilized with or without the air chamber and plunger
- Plunger provides minimum clearance with shock absorption
- Drawbar eye dimensions: 2-3/8" to 3" I.D. with 1-1/4" to 1-5/8" dia. cross section
- Black Powder Coat Finish
- Reduce capacity by 25% for off road applications and use with swivel type trailer drawbar.
- M.G.T.W.: 100,000 lbs.

- M.V.L.: 20,000 lbs.
- **PH50 Interchanges with:**  
Wallace® R50-8  
Holland® PH410
- **PH50AC Interchanges with:**  
Wallace® R50A-8  
Holland® PH410RA11
- Individually boxed

*In Stock for Immediate Delivery*

PART NO.	DESCRIPTION	PROD. CATEGORY	WT.
PH50	Pintle Hook, 50-Ton	525	28.9 lbs.
PH50AC	Pintle Hook, 50-Ton with Air Chamber & Plunger	525	44.8 lbs.
PH50ACMK	Chamber Kit, Air Chamber & Bracket	525	15.9 lbs.
3015603	Bracket, Chamber Mount, ZN	525	3.34 lbs.
3003905	Brake Chamber Only, Type 24	525	8.42 lbs.

Pricing is consistent with current market conditions and is subject to change without notice.