

# Installation Instructions

## Tailgate Air Cylinder

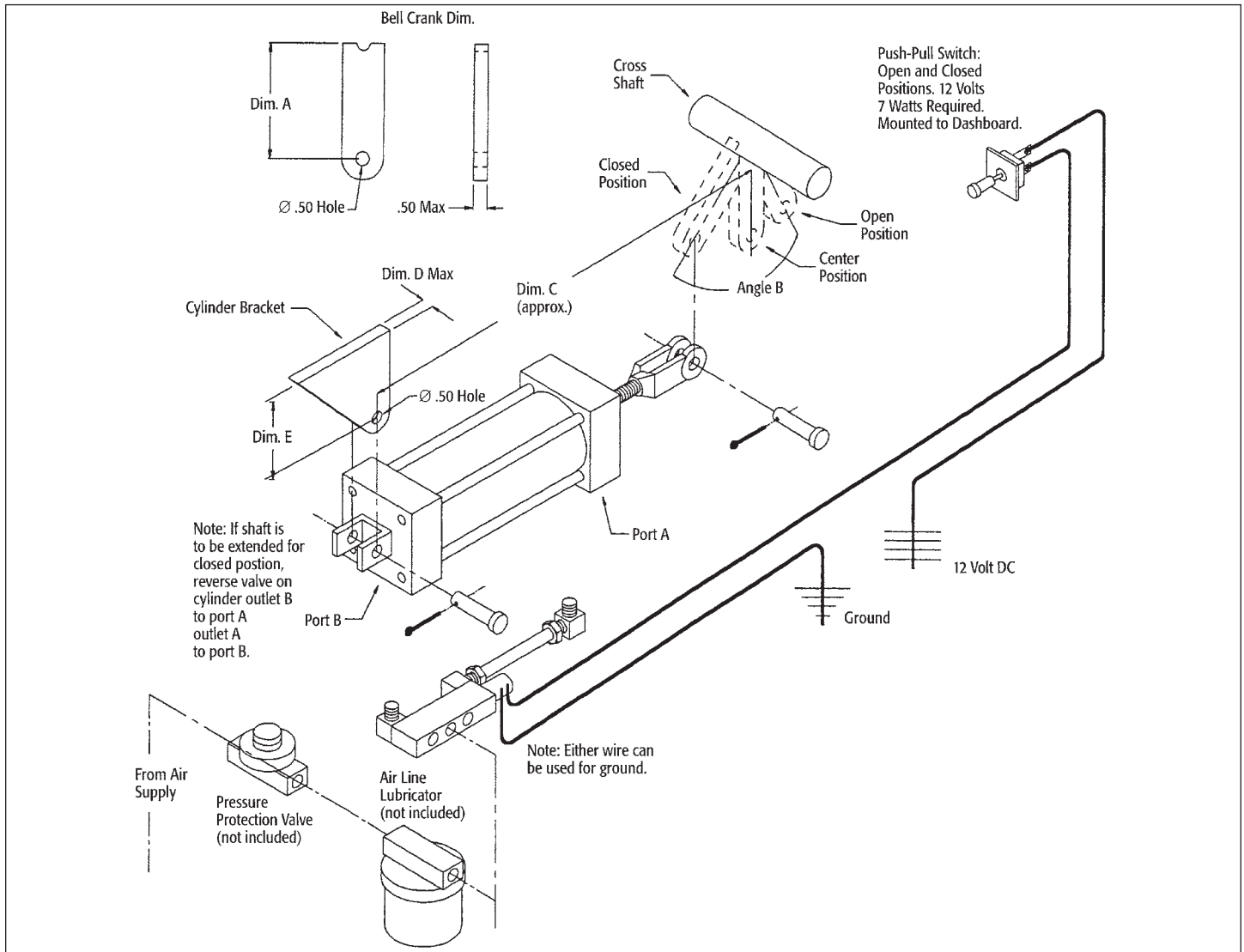

This kit and/or cylinder is designed to allow remote cab opening and closing of the tailgate locking mechanism on a dump body.

Use the following steps to install the air cylinder to the underside of the dump body:

**1.** Construct a bell crank and cylinder bracket using A and E dimensions shown on the table. The bell crank length must cause the shaft to rotate to the “over center” position throughout the full travel of the air cylinder’s stroke. This

PART NO.	AIR CYL. STROKE	DIM. A	ANGLE B	DIM. C	DIM. D	DIM. E
TGC25006V	6"	4.2"	91°	17.25"	.50"	2.25"
TGC25008V	8"	5.6"	91°	20.25"	.50"	2.25"
TGC32506V	6"	4.2"	91°	18.25"	.50"	3.00"
TGC32508V	8"	5.6"	91°	21.25"	.50"	3.00"
TGC25X06TRCV	6"	4.2"	91°	16.00"	.38"	2.25"
TGC25X08TRCV	8"	5.6"	91°	18.00"	.38"	2.25"
TGC35X06TRCV	6"	4.2"	91°	17.50"	.50"	3.00"
TGC35X08TRCV	8"	5.6"	91°	19.50"	.50"	3.00"

will mechanically lock the tailgate. **The air pressure will not lock the tailgate. The “over center” position of the tailgate latches provides mechanical locking.**

—continued on other side

- Align the bell crank and cylinder bracket with the centerline of the air cylinder. This prevents unnecessary torque and twisting of the air cylinder mounts.
- Weld the bell crank to the cross shaft of the dump body as well as the cylinder bracket to the under side of the dump body. Use the C dimension listed in the table for proper spacing.
- Connect the air cylinder to the bell crank and cylinder bracket with two clevis pins.

- Route the air line tubing and switch wires around the hinging action at the rear of the dump body.
- Mount the switch in a convenient location on the dashboard in the cab of the truck.
- Buyers Products Co. recommends that the truck's air line system is equipped with an air line lubricator and a pressure protection valve to promote proper and safe operation as well as extending life for the air cylinder and control valve.

Replacement Parts Kits for:  
 TGC25X06TRCV, TGC2508TRCV  
 Air Cylinders

KIT PART NO:	ITEM NO. & QTY.			
	1	2	3	4
TGC25XFCK	1	2	-	-
TGC25XRCK	-	2	-	1
TGC25XPRK	-	2	1	-

Replacement Parts Kits for:  
 TGC25006V, TGC25008V,  
 TGC32506V, TGC32508V  
 Air Cylinders

KIT PART NO:	ITEM NO. & QTY. IN KIT					
	1	2	3	4	5	6
<b>KITS FOR 2-1/2" AIR CYLINDERS</b>						
TGC25008CKRK	1	-	1	2	2	1
TGC25008CKBK	1	1	1	-	-	-
<b>KITS FOR 3-1/4" AIR CYLINDERS</b>						
TGC32508CKRK	1	-	1	2	2	1
TGC32508CKBK	1	1	1	-	-	-

Replacement Parts Kits for:  
 TGC35X06TRCV, TGC3508TRCV  
 Air Cylinders

CYLINDER P/N	REPLACEMENT KIT P/N				
	1*	2	3	4	5
TGC35X06TRCV	TGC35XSK	TGC35XFC	TGC35X06R	TGC35XP	TGC35XRC
TGC35X08TRCV	TGC35XSK	TGC35XFC	TGC35X08R	TGC35XP	TGC35XRC

\*SEAL KIT IS NEEDED FOR PROPER REPLACEMENT OF ANY OTHER COMPONENT

**Warranty**

Buyers Products Co. warrants all truck/trailer hardware manufactured or distributed by it, to be free from defects in material and workmanship for a period of one year from date of shipment. Parts must be properly installed and used under normal conditions. Any product which has been altered, including modification, misuse, accident or lack of maintenance will not be considered under warranty. Normal wear is excluded. The sole responsibility of Buyers Products Co. under this warranty is limited to repairing or replacing any part or parts which are returned, prepaid, and are found to be defective by Buyers Products Co. Authorization from Buyers Products Co. must be obtained before returning any part. No charges for transportation or labor performed on Buyers' products will be allowed under this warranty.